

Features:

- Switch 6 ports 4 PoE ports 10/100Mb/s (data transfer and power supply)
2 ports 10/100Mb/s (UP LINK)
- **Long Range** mode (up to 250m)
- 30 W for each PoE port, supports devices compliant with the IEEE802.3af/at (**PoE+**) standard
- Supports auto-learning and auto-aging of MAC addresses (1K size)
- The PSD 520115 52 V DC/1,15 A/60 W max. power supply desktop type included
- Additional assembly elements
- LED indication
- warranty – 2 year from the production date

Example of use.

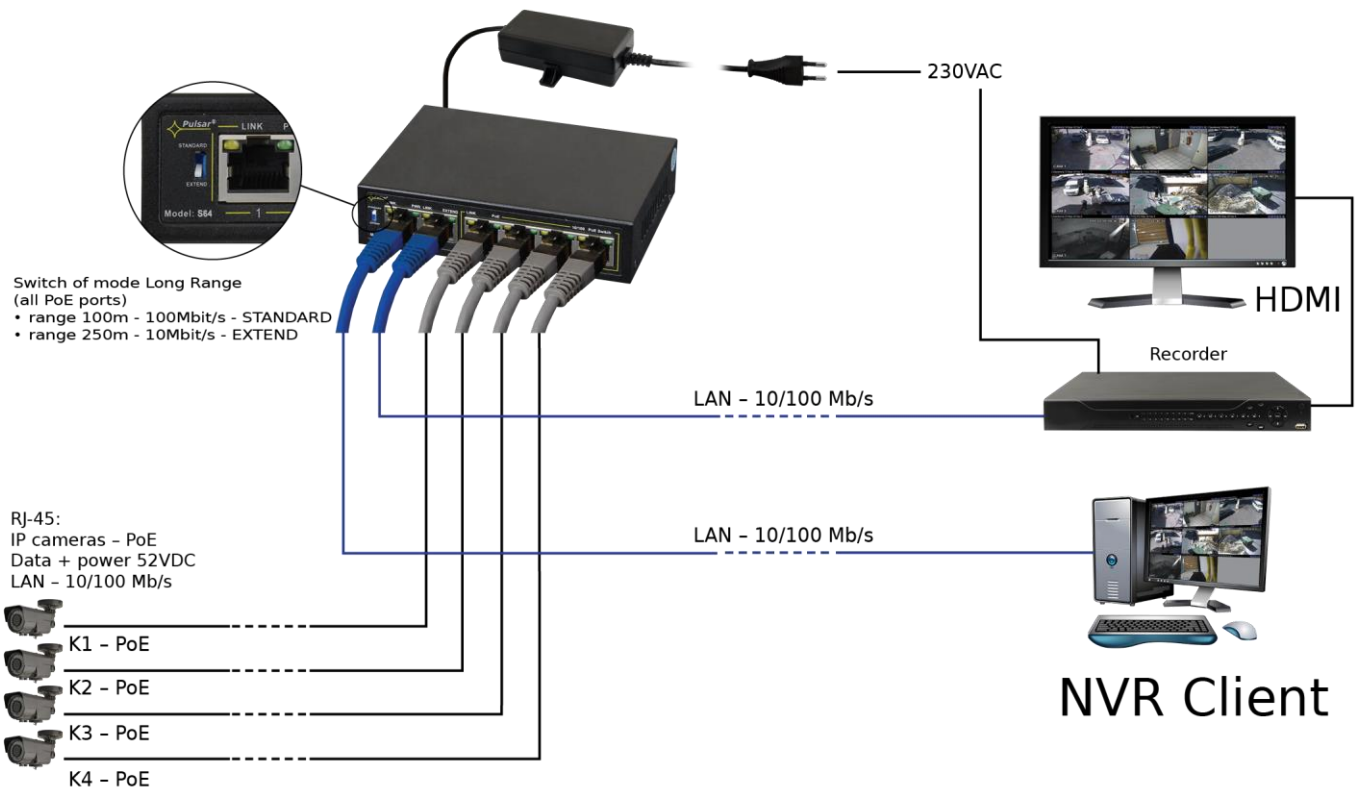

1. Technical description

1.1. General description.

S64 is a 6-ports PoE switch designed to supply IP cameras operating in IEEE 802.3af/at standard.

Automatic detection of any devices powered in the PoE/PoE+ standard is enabled at the 1 – 4 ports of the switch. The UP LINK ports is used for connection of another network device via RJ45 connector. The LEDs at the front panel indicate the operation status (description in the table below).

The PoE technology ensures a network connection and reduces installation costs by eliminating the need to supply a separate power cable for each device. This method allows supplying other network devices, such as IP phone, wireless access point or router.

1.2 Block diagram.

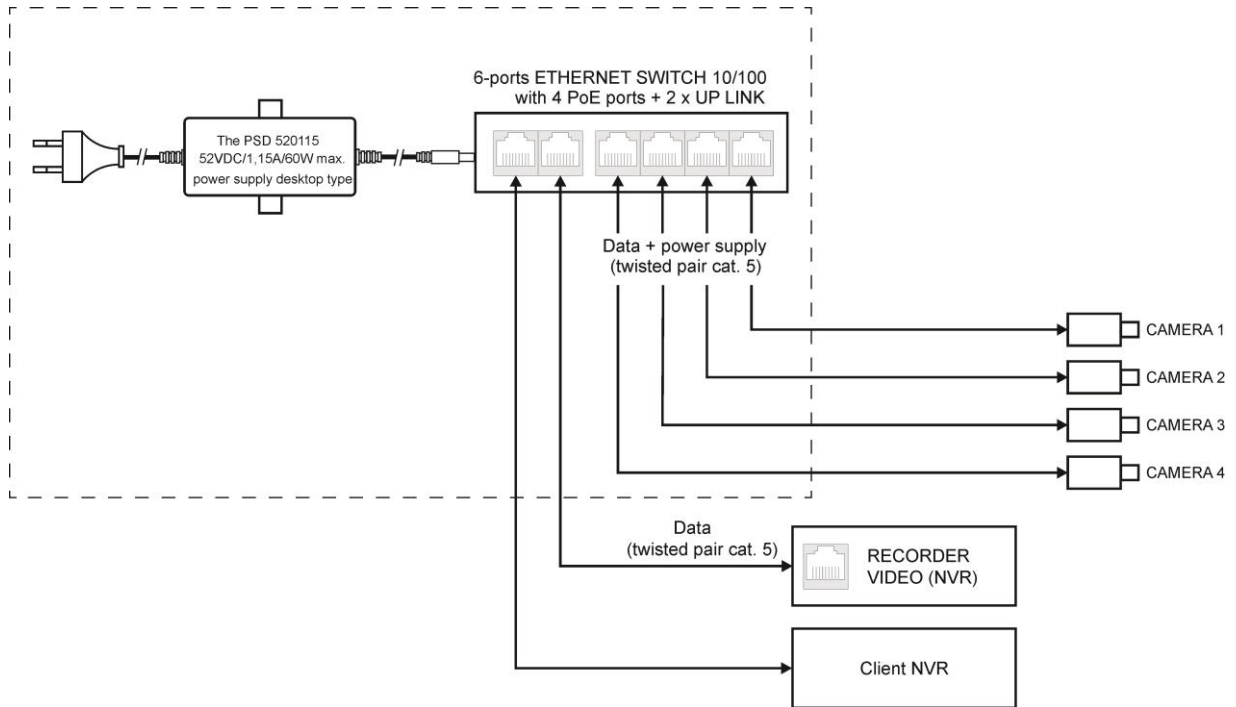

Fig. 1. Block diagram.

1.3 Description of components and connectors.

Table 1. (see Fig.2)

Element no. (Fig. 2)	Description
[1]	2 x UP LINK port
[2]	4 x PoE port (1÷4)
[3]	Power Socket of the DC
[4]	Additional mounting elements
[5]	Switch of mode Long Range

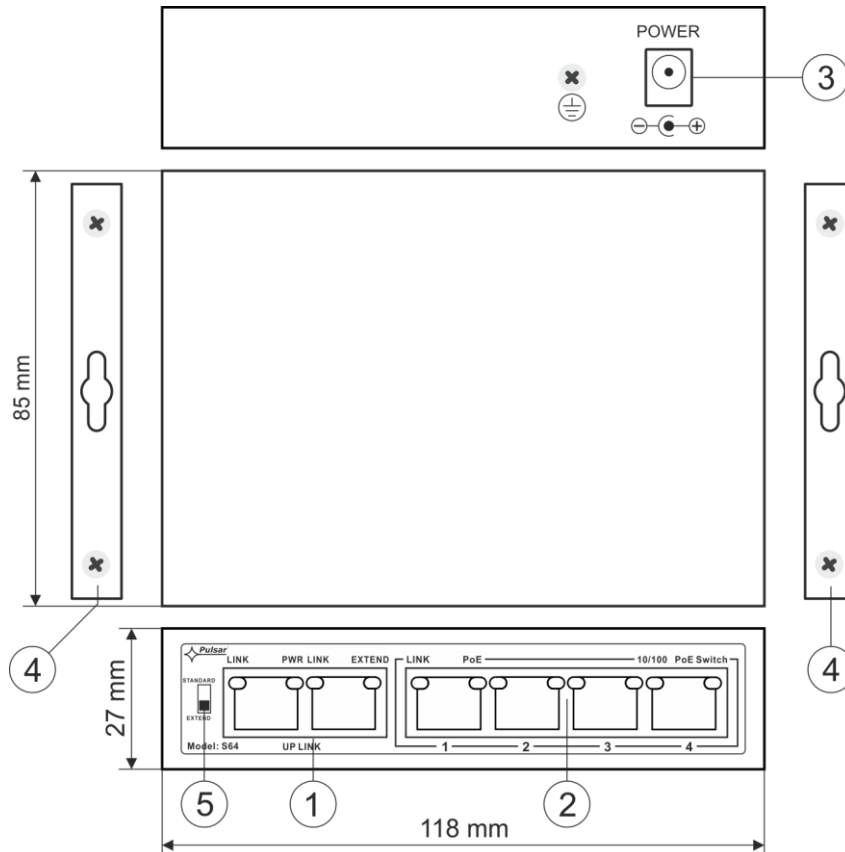

Fig. 2. The view switch'a.

1.4. Technical parameters.

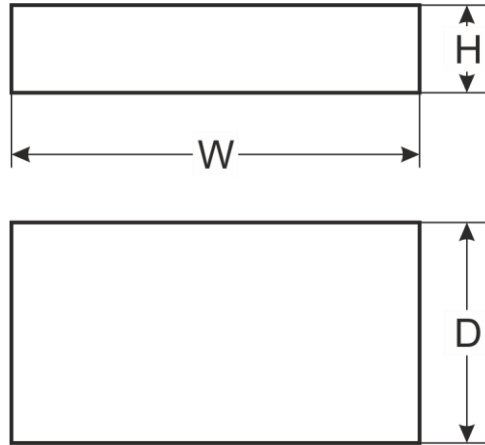

Table 2.

Ports	6 10/100Mb/s ports (4 x PoE + 2 x UP LINK) with connection speed auto-negotiation and MDI/MDIX Auto Cross
PoE power supply	IEEE 802.3af/at (1+4 ports), 52 V DC / 30 W at each port *
Long Range mode	Long Range, VLAN
Protocols, Standards	IEEE802.3, 802.3u, 802.3x CSMA/CD, TCP/IP
Bandwidth	1,6Gbps
Transmission method	Store-and-Forward
Optical indication of operation	Switch power supply; Link/Act; PoE Status
Power supply	~100-240 V; 50/60 Hz; 1,3 A the PSD 520115 52 V DC / 1,15A/60 W max. power supply desktop type
Operating conditions	temperature -10°C ÷ 40°C, relative humidity 5% - 90%, no condensation
Dimensions	W=118, H=28, D=85 [+/- 2mm]
Additional equipment	plate to be fixed surface
Net/gross weight	0,5/ 0,7kg
Protection class EN 60950-1:2007	II (second)
Storage temperatur	-20°C ÷ 60°C
Declarations	CE

* The given value of 30 W per port is the maximum value. The total power consumption should not exceed 48 W.

2. Installation

2.1. Requirements

The unit should be mounted in confined spaces, in accordance with the 2nd environmental class, with normal relative humidity (RH=90% maximum, without condensation) and temperature from -10°C to +40°C. Ensure the free flow of air around the unit. The PSU shall work in a vertical position that guarantees sufficient convectional air-flow through ventilating holes of the enclosure.

The load balance should be done before installation Switcha. The given value of 30 W per port is the maximum value referring to a single output. The total power consumption should not exceed 48 W. The increased demand for power is particularly evident in the case of cameras with heaters or infrared illuminators - when launching these features, the power consumption increases rapidly, which may adversely affect the operation of the switch. The device is designed for a continuous operation and is not equipped with a power-switch. Therefore, an appropriate overload protection in the power supply circuit should be provided. The electrical system shall be made in accordance with applicable standards and regulations.

2.2. Long Range mode

Switch enables operation in two modes: standard and extended range. When the Long Range switch is in STANDARD position (see Fig. 5), PoE ports operate at 100 Mb / s up to 100 meters. After switching to EXTEND position, range is increased to 250 meters and speed is reduced to 10 Mb / s. Additionally, VLAN function, which isolates the PoE ports between each other (communication takes place between the UpLink ports and individual PoE), is activated. In both modes, the UpLink port speed is 100 Mb / s.

Note: Changing the modes requires a power restart!

2.3. Installation procedure

1. Connect switch to the PSD520115 52 V DC power supply unit desktop type.
2. Connect the power supply to the AC 230 V socket.
3. Connect the camera wires to the RJ45 connectors (PoE connectors).
4. Check the optical indication of switch operation (see Table 3).

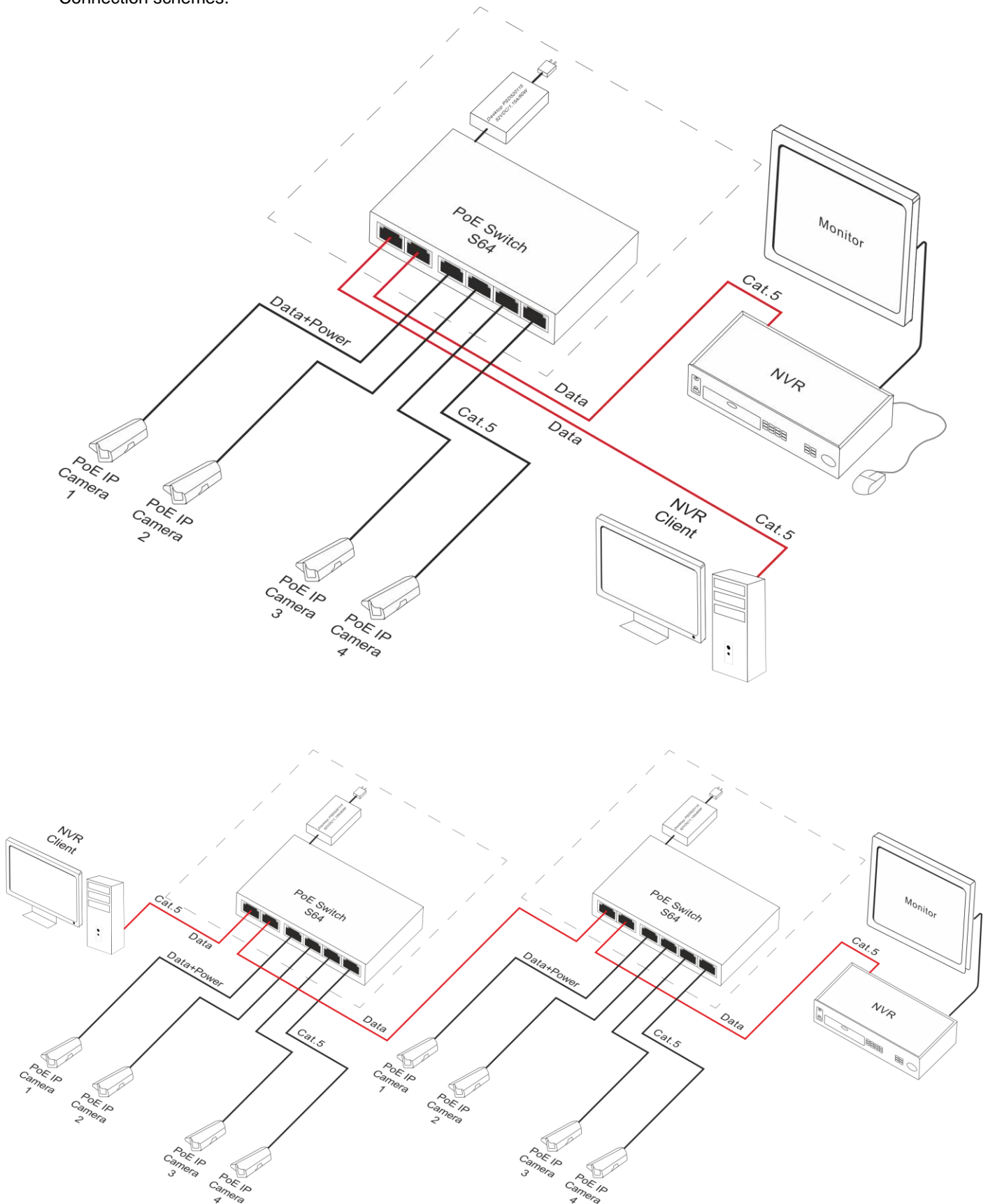

Connection schemes.





3. Operation indication.

Table 3. Operation indication

OPTICAL INDICATION AT THE PoE PORTS (1÷4)

<p>GREEN LED LIGHT (PoE) Indication of the PoE power supply at the RJ45 ports</p>		<p>OFF- no power supply at the RJ45 port (the device is not connected or not compliant with the IEEE802.3af/at standard) ON – supply at the RJ45 port Blinking – short-circuit or output overload</p>
<p>YELLOW LED LIGHT (LINK) The connection status of LAN devices, 10MB/s or 100Mb/s and data transmission</p>		<p>OFF- no connection ON - the device is connected; 10Mb/s or 100Mb/s Blinking – data transmission</p>

OPTICAL INDICATION AT THE UP LINK PORTS

<p>GREEN LED LIGHT</p>		<p>Port on the left side: No lit - no voltage Lit – switch operates properly</p>	<p>Port on the right side: No lit – switch operates in normal mode Lit– Long Range mode active</p>
<p>YELLOW LED LIGHT (LINK) The connection status of LAN devices, 10MB/s or 100Mb/s and data transmission</p>		<p>OFF- no data transmission ON - the device is connected; 10Mb/s or 100Mb/s Blinking – data transmission</p>	

WEEE LABEL



Waste electrical and electronic equipment must not be disposed of with normal household waste. According to the European Union WEEE Directive, waste electrical and electronic equipment should be disposed of separately from normal household waste.

Pulsar sp. j.

Siedlec 150, 32-744 Łapczyca, Poland
Tel. (+48) 14-610-19-40, Fax. (+48) 14-610-19-50
e-mail: biuro@pulsar.pl, sales@pulsar.pl
http:// www.pulsar.pl, www.zasilacze.pl